

Guidance on how to comply with the 2010 Building Regulations Part L

Version 2.0 – 10 December 2010

This guide supports the official guidance covering the use of controls in boiler based, gas and oil fired domestic central heating installations within the revised Building Regulation Part L1 for England and Wales, which came into force from October 1 2010.

If followed, the guidance and recommended system layouts will provide confidence that designs and installations fully comply with the relevant parts of the Building Regulations.

For further information contact TACMA via email: BRegs@beama.org.uk

These regulations apply to all dwellings including “houses in multiple occupation” (HMOs) – for example bedsits – which are dwellings shared by several people who are not members of the same family but who share a kitchen or WC. They do not apply to a “room for residential purposes”, which is defined as “a room or suite of rooms which is not a dwelling-house or flat and which is used by one or more persons to live and sleep in, including rooms in hotels, hostels, boarding houses, halls of residence and residential homes.”

This guide has been prepared by members of TACMA, the association for UK manufacturers and suppliers of electrical and electronic controls and switches used in appliances, heating systems and general purpose applications. Its members are Danfoss Randall, Honeywell Control Systems Ltd, Horstmann Controls Ltd, Invensys Controls, Myson Heating Controls, Pegler Yorkshire, Siemens, Sunvic Controls Ltd.

TACMA is dedicated to advancing heating controls for domestic installations to ensure a comfortable environment at the least cost.

TACMA, Westminster Tower, 3 Albert Embankment, London, SE1 7SL

Specific compliance for heating and hot water controls with a gas or oil boiler

New for 2010

- All new systems in dwellings that aren't open plan must have at least two heating zones, each controlled by a thermostat and zone valve. In addition, all radiators must have Thermostatic Radiator Valves (TRVs) fitted except those in rooms with a room thermostat and those in bathrooms.
- When replacing a boiler in an existing system it is now good practice to install TRVs on all radiators except those in rooms with a room thermostat and those in bathrooms while the system is drained down.

Areas covered by the regulations	Requirements in the regulations	Suitable installations for compliance ⁱ	Exemptions/recommendations
Heating – temperature control	1. The dwelling must be divided into at least two heating zones ⁱⁱ	a) A zone valve on the pipework to control the flow to each zone	Single story open-plan dwellings in which the living area is more than 70% of the total floor area can be controlled as one zone.
	2. Each zone must have temperature control with both a thermostat and individual radiator controls such as TRVs.	<i>Either:</i> a) A room thermostat or programmable room thermostat in each zone, <u>plus</u> thermostatic radiator valves (TRVs) on all radiators except bathrooms and rooms with a thermostat. b) A centrally controlled system of TRVs on each radiator that can be demonstrated to provide interlock when no heat is required.	Where only the boiler is replaced, compliance with zone requirements can be achieved by a single room thermostat or programmable room thermostat <u>plus</u> TRVs on all radiators except the one in the room with the thermostat. Installation of TRVs when the system is drained down should always be done except where the radiators or pipework make this impractical.
Heating and Hot water - Time control	1. The dwelling must have automatic time control so that the heating and hot water system is turned on and off at set times which can be adjusted by the occupant(s). Time control must be provided as follows: i) Dwellings up to 150m ² where the hot water is produced instantaneously only require a single time control circuit. ii) Dwellings up to 150m ² where there is a hot water cylinder require separate time control for the heating and for the hot water. iii) Dwellings over 150m ² require separate time control for the hot water (unless instantaneous) and separate time control for each heating zone. ⁱⁱⁱ	All required timed circuits must have independent time control. This can be achieved through <i>either</i> : a) A separate timer or programmer on each circuit. b) A full programmer with separate timing of heating and hot water. c) A programmable room thermostat on each timed heating circuit plus a timer on the hot water circuit. d) A multi-channel programmer providing full control of each timed circuit from a central point.	Where only a hot water cylinder is being replaced it is acceptable to have a single timing control for both space and water heating. However, if separate time control for hot water is present in such a situation then the new installation must retain this level of control.

Hot water – temperature control	<ol style="list-style-type: none"> 1. The dwelling should have control of the temperature of any stored hot water. 2. Dwellings over 150m² should have more than one hot water circuit with separate time and temperature control for each circuit. 	<ol style="list-style-type: none"> a) A cylinder thermostat with a zone valve or three port valve. b) In some circumstances such as thermal stores a second pump should be substituted for the zone valve. 	Where only a hot water cylinder is being replaced in an emergency situation (i.e. non-planned) either a wireless or thermomechanical hot water cylinder thermostat should be installed as a minimum.
Hot water supply – temperature control	The hot water supply to any fixed bath must be so designed and installed as to incorporate measures to ensure that the temperature of the water that can be delivered to that bath does not exceed 48°C.	A Thermostatic Mixing Valve should be installed and it is recommended that this be set to deliver hot water to the bath at 43°C.	Only applies in new dwellings or through a material change of use of an area within an existing dwelling, e.g. a new bathroom.

Summary of general requirements for all heating and hot water systems with a gas or oil boiler

(These requirements apply for both the installation of new systems and when replacing a boiler unless specifically mentioned as an exemption.)

1. Install the system with fully pumped circulation. When replacing a boiler in an existing system with semi-gravity circulation convert the system to fully pumped circulation.
2. Install an automatic bypass valve where manufacturer’s instructions advise installation of a bypass. TACMA does not recommend the installation of an automatic bypass valve if the boiler is of a fully modulating type.
3. Install a ‘boiler interlock’ so that the boiler and pump are switched off when there is no demand for heating or hot water. This is achieved by correct wiring of the room thermostats or programmable room thermostats, the cylinder thermostat and zone valves in conjunction with the timing device(s.) The use of traditional TRVs alone does not provide interlock though some systems of programmable TRVs can do so – check manufacturers data for information.

Additional requirements for installations

1. On completion of the installation all equipment should be commissioned in accordance with the manufacturers’ instructions. The operation of all controls should be tested and the distribution system should be fully balanced to ensure correct operation of the thermostatic radiator valves.
2. The installer must also give a full explanation of the system and its operation to the user. This will include a description of how to use all of the controls and the relevant User Instructions must be left with the user. For new systems in existing homes the Part L approved document states that “a way of complying would be to provide a suitable set of operating and maintenance instructions aimed at achieving economy in the use of fuel and power in terms that householders can understand in a durable format that can be kept and referred to over the service life of the system(s).”

Controls upgrades in existing homes

While upgrades to controls in existing heating systems, other than at times of boiler replacement, are not specifically required under the building regulations it is good practice for all homes to have a set of controls that at least complies with the minimum standards in the Building Regulations – a boiler interlock, room thermostat, programmer, thermostatic radiator valves and a hot water cylinder thermostat. These will ensure that the existing heating system is not operating inefficiently and allow the occupants to make further reductions in their energy costs through behaviour change.

Heating installers should recommend controls upgrades as required to meet these standards when visiting homes for maintenance and repairs. UK Government is committed to reducing energy use in homes and householders should be reminded that 84% of energy use in homes is from heating and hot water.

Wireless controls are a convenient choice for controls upgrades; allowing ease of installation and minimal disruption by taking away the requirement for wiring runs.

ⁱ Control may be provided by any boiler management system that meets the specified zoning, timing and temperature and boiler interlock control requirements.

ⁱⁱ One zone must cover the 'living area' and heating zones will often be divided to cover 'living' and 'sleeping' areas, or upstairs and downstairs. There are usually significant opportunities for energy saving by matching zones to the lifestyle of occupants (for example with home offices) and installers should look for opportunities to set up zones beyond the minimum requirements.

ⁱⁱⁱ A 2006 report by Nationwide showed that most four-bedroom detached houses fall into this category with the average floor area of such properties being 157m² (the average for five-bedroom detached was over 200m².) Older houses can be larger than modern ones, with the average of all pre-war detached homes being over 150m².

Example layouts for new systems to ensure compliance

Dwellings up to 150m²

Boiler with hot water cylinder

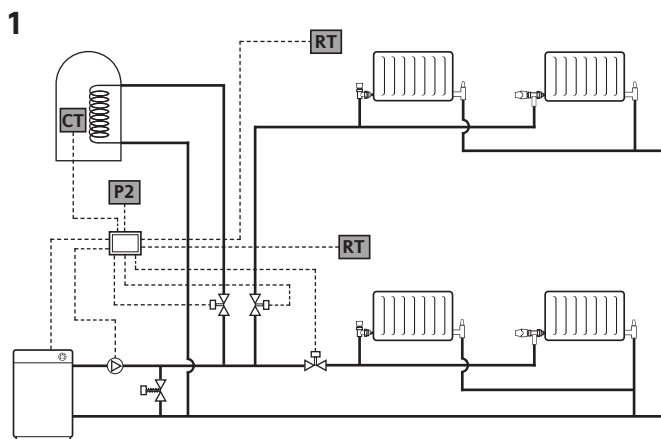

Combination boiler

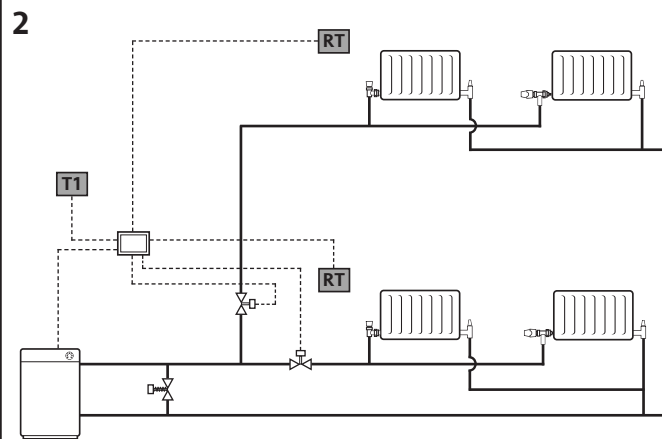

Programmer, room thermostats and TRVs

Timeswitch, room thermostats and TRVs

Dwellings over 150m²

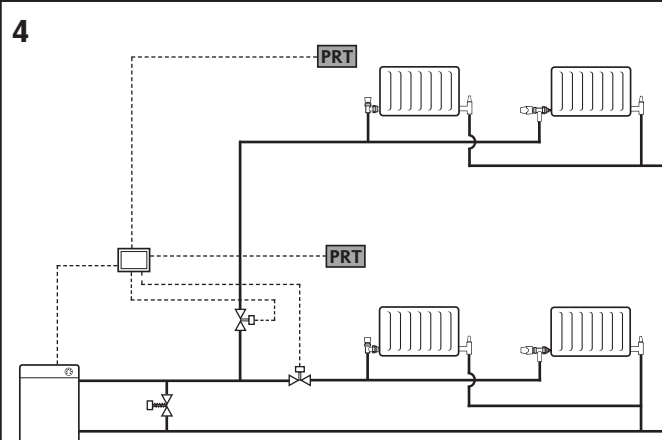
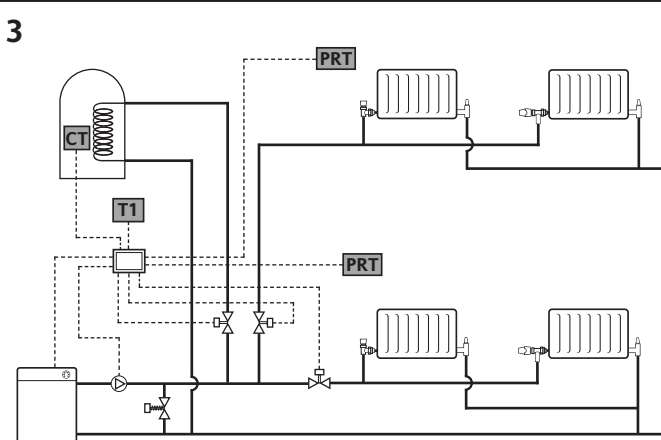

Programmable room thermostats and TRVs

Programmable room thermostats and TRVs

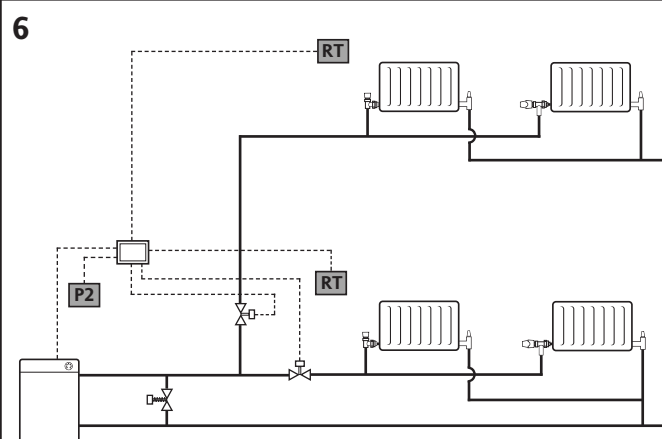
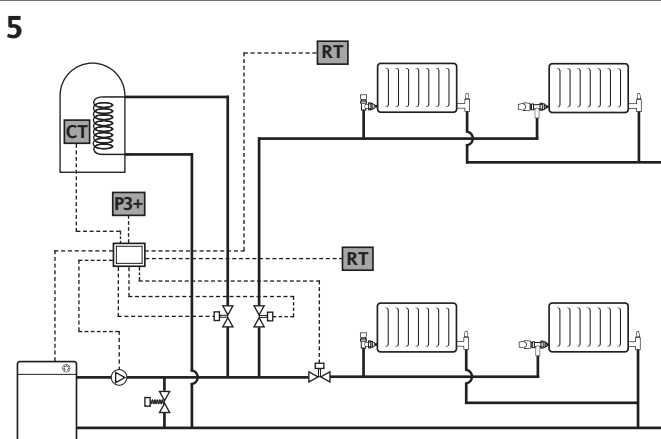

Multi-channel programmer, room thermostats and TRVs

Two heating zone programmer, room thermostats and TRVs

KEY TO SYMBOLS

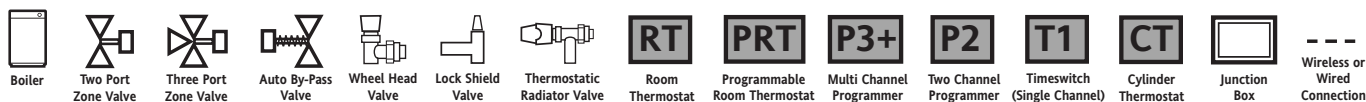

NOTES

- Systems specified for dwellings over 150m² will also satisfy compliance for smaller dwellings.
- Where zone valves are installed in smaller dwellings it is always recommended that both time and temperature control of zones are applied. This can be done for little additional cost but provides far more flexible control options for the occupants.
- All of these systems are preferable approaches where only the boiler is replaced. However pipework changes can incur significant additional work in existing homes so the simplified example layouts for replacement boilers will meet compliance in such circumstances.

Example layouts for replacement boilers to ensure compliance

Boiler with hot water cylinder

2 port valve control

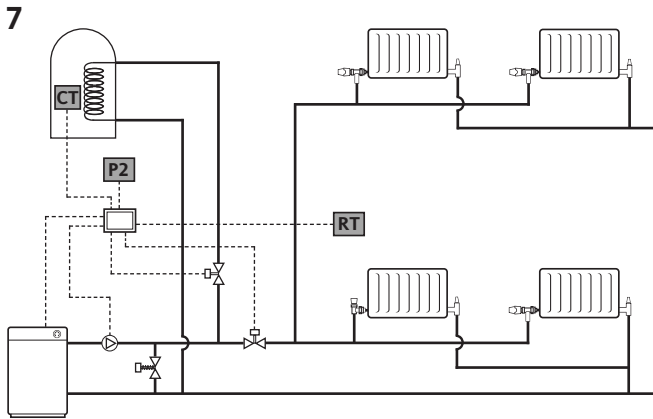

3 port valve control

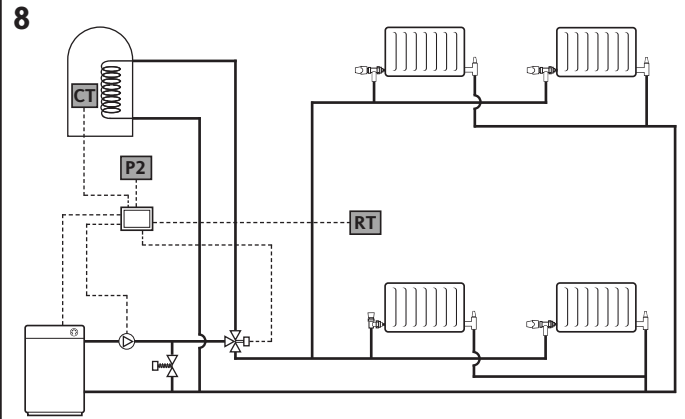

Programmer, room thermostat and TRVs

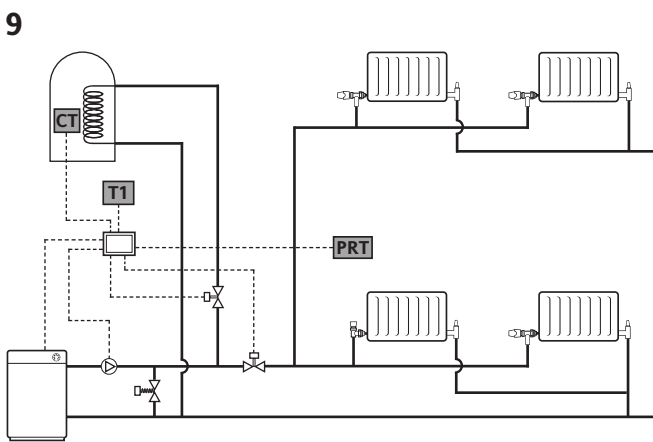

Programmer, room thermostat and TRVs

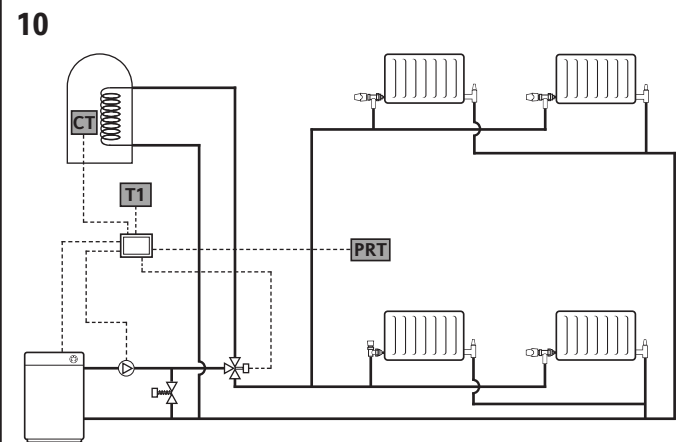

Programmable room thermostat and TRVs

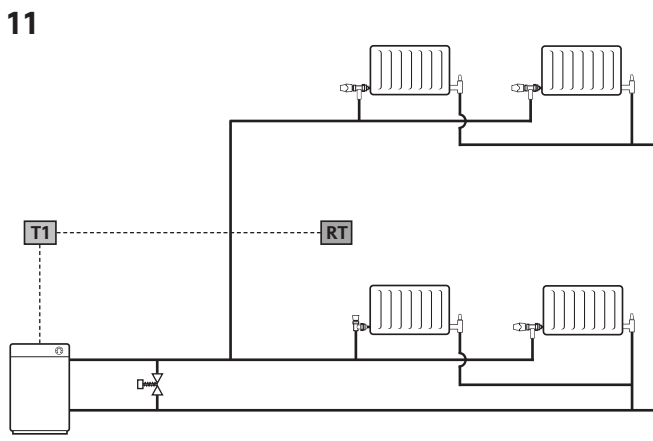

Programmable room thermostat and TRVs

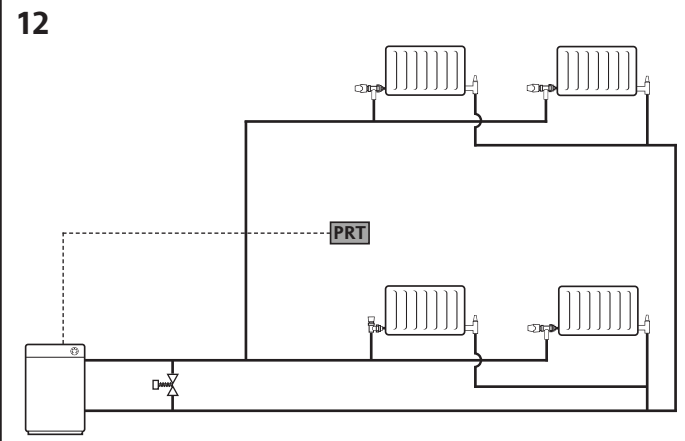

Combination boiler

Timeswitch, room thermostat and TRVs

Programmable room thermostat and TRVs

KEY TO SYMBOLS

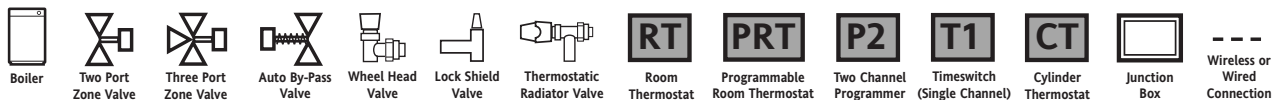

NOTES

- Where the system is of a semi-gravity type and therefore requires conversion to a fully pumped system consideration should be given to adoption of the system layouts specified for new systems.
- It is defined good practice to fit thermostatic radiator valves to all radiators when the system is drained down. TACMA recommends that this should always be done unless the type of existing radiators or pipework layouts makes it impractical.